

# A responsible use of power



## Lighting just became less expensive to operate

### The innovation of fluoresave

Fitted at or near the main distribution board, **fluoresave** is a microprocessor controlled, energy saving unit for use with fluorescent and discharge lighting such as sodium, mercury and metal halide and requires no changes to lights or fittings.

The **fluoresave** unit supplies mains voltage to the lights for ignition. The unit allows a short time delay period for lamp warm-up to ensure stable operation of the lights, before switching to a lower energy saving voltage. Each unit comes factory set to reduce the voltage by 15% for maximum savings, however for certain types of lamps a 12½% or 10% reduction may be simply selected.

Single or multiple lighting circuits and mixed lamp types can be controlled by a single **fluoresave** unit making it very versatile and economic to install.

During operation, **fluoresave** continuously monitors the variation in the output of the current and mains voltage. When additional lights within the circuit are switched on, **fluoresave** will revert back to mains voltage for ignition and wait for the current to stabilise before returning to the energy-saving mode.

### Power savings of 30% or more

Independent electrical auditors have tested **fluoresave** in the workplace and compared power consumption before and after connection of **fluoresave**. The auditors confirmed that

the power required to operate the lamps was reduced by more than 35% with little discernable loss in lux levels.

Experiences of **fluoresave** users in many buildings with varying lighting types have shown savings of 30% and more when applied to fluorescent lighting and in excess of 20% when used with other discharge lighting. (**fluoresave** will not make savings when used with high frequency lighting or lighting controlled by an electronic ballast).

In new installations where fluorescent lighting is required, **fluoresave** combined with switch-start fluorescent lighting will show significant cost and performance advantages over high frequency fluorescent lighting, and **fluoresave** generates no harmonics.

### Make immediate savings

Government, industry, business, commerce, factories, warehouses, hospitals, education establishments and the retail sector are all high volume users of lighting. **fluoresave** offers an enormous opportunity to simply and decisively reduce unnecessary energy consumption and its associated costs, sending the savings straight to the "bottom line".

### Environmental benefits

**fluoresave** reduces the energy required to operate lighting, which in turn reduces the impact on the environment.

By reducing the voltage to the lamps, **fluoresave** reduces their running temperature thus extending their life considerably. This has a valuable impact on lamp replacement costs and on the environmental impact of lamp disposal.

The burning of fossil fuels for electrical power production generates enormous greenhouse gas emissions such as carbon and other environmentally destructive elements. The Kyoto World Greenhouse Gas Emissions Agreement requires Europe to reduce carbon emissions. The beneficial effects of reducing the environmental impact of energy creation cannot be understated. For users, **fluoresave** can aid ISO 14001 compliance and offer possible carbon trading opportunities.

### Benefits

- Saves up to 30% on power consumption
- Lamp life extended by approx 25% +
- Generates No Harmonics
- Easy to install in existing buildings
- Light fittings do not require modification
- No disruption to working environment
- Reduces cost of Climate Change Levy
- Aids ISO 14001 compliance
- 2 Year Warranty

# General specifications

## Specifications

Model No.	D12	D20	D32
-----------	-----	-----	-----

Maximum rating:	12Amp	20Amp	32Amp
-----------------	-------	-------	-------

Maximum Load:	2880VA	4800VA	7680VA
---------------	--------	--------	--------

Maximum current for lamps using induction ballast:	12Amp	20Amp	32Amp
--	-------	-------	-------

Weight:	7 Kg	8.5 Kg	12 Kg
---------	------	--------	-------

### External dimensions:

12 Amp model - 350mm x 190mm x 120mm

20 Amp model - 350mm x 220mm x 120mm

32 Amp model - 400mm x 260mm x 160mm

## Security and Reliability

Electronic fault protection circuitry detects and protects the **fluoresave** unit from adverse supply and load conditions. Indicator lights on the front of the unit show its operating mode and indicate any operating fault. An inbuilt failsafe device bypasses the **fluoresave** unit in the unlikely event of failure, reverting to mains power supply to maintain the lighting. **fluoresave** has proved, after a number of years of service around the world, to be highly reliable, requiring no service or maintenance.

Warranty (Conditions apply) a 2 year full replacement warranty applies to all models.

## Operation conditions

Input Voltage: 230 Volts AC  
(if supply voltage falls below 192V, **fluoresave** will maintain mains voltage)

Frequency: 50/60Hz single phase with earth

Enquiries:

Utiligy

e-mail: sales@utiligy.com.au  
website: www.utiligy.com.au  
Fax: 0 3 8699 8700  
Tel: 0 3 8699 8799

## Typical Installation

Installation of the **fluoresave** unit is between the power distribution board and the light circuits. Each **fluoresave** unit will run multiple lights and light circuits, the number limited only by the capacity of the **fluoresave** model chosen.

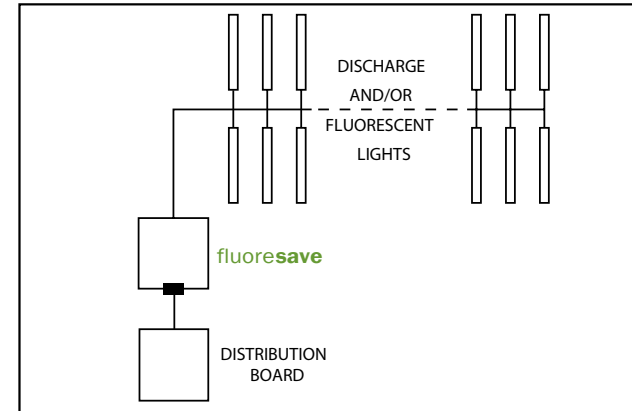

## Wiring Connections within **fluoresave** unit

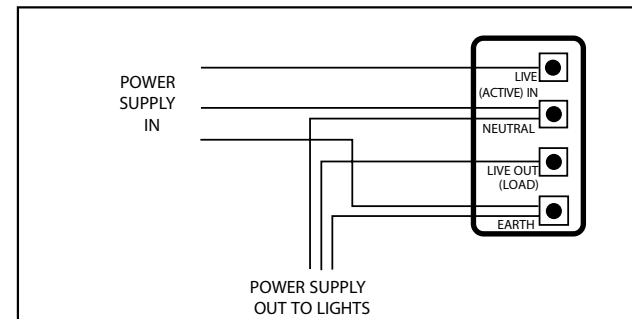

## Compliance - "CE" conformity for Europe

**fluoresave** models D12, D20 & D32 comply with the following C E Directives and Standards:-

CE89/336/EEC Electro-Magnetic Compatibility Directive

(Amended by 92/31/EEC & 93/68/EEC)

EN50081-1:1992, EN50082-1:1998, EN61000-3-2:2000, EN61000-3-3:1995.

73/23/EEC Low Voltage Equipment Directive

(Amended by 93/68/EEC)

BSEN50178:1998, BSEN61010:1:2001.

German Standard - VDE Certificate of Conformity with factory surveillance Reg Nr. A873

Australasian Standards - AS/NZS4051, AS/NZS3100:2002, AS/NZS60335

## Example of Cost Benefit

Using a **fluoresave** (Model D20) 20 Amp unit, in an office, powering 34 twin 58 watt fluorescent light fittings for 12 hours per day, at a cost 5p per unit of electricity (Kw/hr) typically the unit will pay for itself from the savings within 12 months.

**fluoresave**

A RESPONSIBLE USE OF POWER



Cut energy costs  
on your lighting  
Reduce CO<sub>2</sub> emissions

**fluoresave**

A RESPONSIBLE USE OF POWER